

TopMap Micro.View®

TopMap Micro.View® is an easy to use and compact optical profiler. Combine exceptional performance and affordability with this powerful metrology solution. This white-light interferometer with an extended 100 mm z measurement range with Continuous Scanning Technology (CST) allows complex topographies to be measured at nm resolution. This convenient table-top setup features integrated electronics, with the smart focus finder simplifying and speeding up the measurement procedure.

Benefit from the optional ECT Environmental Compensation Technology, enabling reliable and accurate measurement results even in noisy and challenging production environments. Micro.View® is the cost-effective quality control instrument for inspecting precision engineered surfaces in the field of manufacturing and research.



Highlights

- Measure surface finish in a compact setup
- Non-contact measurement of 3D topography, roughness and texture
- 100 mm Z measurement range with CST Continuous Scanning Technology
- Excellent lateral resolution
- Determine surface defects
- Choose from application-specific objectives

TopMap Micro.View®

Table-top optical surface profiler

Datasheet



Technical data

The information for the model TMS-1400 TopMap Micro.View® comply with the initiative "Fair Data Sheet" for optical surface measurement devices.



General features ¹

Positioning volume ² 100 x 75 x 75 mm³ = 0.00056 m³

Max. number of measuring points in a single measurement X: 1352, Y: 1000, X·Y: 1 352 000

Max. number of measuring points in a stitched measurement 500 million

Objective-specific features ¹

	2.5X	4X LWD	5X	10X	20X	50X	100X
X: mm, Y: mm, X·Y: mm ²	X: 3.17	X: 1.98	X: 1.59	X: 0.79	X: 0.39	X: 0.16	X: 0.08
	Y: 2.34	Y: 1.47	Y: 1.17	Y: 0.58	Y: 0.29	Y: 0.12	Y: 0.06
	X·Y: 7.43	X·Y: 2.90	X·Y: 1.86	X·Y: 0.46	X·Y: 0.12	X·Y: 0.019	X·Y: 0.005
Working distance	10.3 mm	30 mm	9.3 mm	7.4 mm	4.7 mm	3.7 mm	2 mm
Vertical measuring range ⁷	60 mm	42 mm	100 mm	100 mm	100 mm	100 mm	100 mm
Numerical aperture	0.075	0.10	0.13	0.30	0.40	0.55	0.70
Calculated maximum angle	4.30°	5.74°	7.47°	17.46°	23.58°	33.37°	44.43°
Measuring point spacing X, Y	2.34 μm	1.47 μm	1.17 μm	0.59 μm	0.29 μm	0.12 μm	0.06 μm
Calculated lateral optical resolution	4.27 μm	3.20 μm	2.46 μm	1.07 μm	0.80 μm	0.58 μm	0.46 μm

Performance features

Measurement noise ^{1,3,4} 0.7 nm

Vertical resolution ^{1,3} 2 nm

Surface topography repeatability ^{3,5} 0.2 nm

Repeatability of RMS ⁶ 0.07 nm

General specifications

Dimensions [L x W x H]

Stand 520 x 575 x 540 mm³

Sensor head 270 x 440 x 182 mm³

Weight

Stand ² 26 kg

Sensor head ⁸ 12.8 kg

Power 100...240 VAC ±10 %, 50/60 Hz, 100 W system + 120 W PC

Ambient temperature range 20 ±3 °C

Operation/Storage temperatur +10 °C ... +35 °C (50 °F ... 95 °F) / -10 °C ... +65 °C (14 °F ... 149 °F)

Relative humidity max. 80 %, non-condensing

¹ Complies with the initiative "Fair Data Sheet" for optical surface measurement devices

² With optional XY-positioning stage

³ Phase evaluation

⁴ According to the initiative "Fair Data Sheet", 30 measurements (10x objective, 16.5 μm/sec, 92% FOV) on a parallelly aligned plane mirror (R > 93%, λ/10). Postprocessing: alignment, 5 x 5 median filter with threshold 3 nm (phase evaluation)/40 nm (envelope evaluation), high pass filter λ_c = 0.25 mm

⁵ According to DIN EN ISO 25178-604:2013-12 30 measurements (10x objective, 16.5 μm/sec, 92% FOV with 3x3 median filter) on a parallelly aligned plane mirror (R > 93%, λ/10)

⁶ Repeatability of the surface roughness parameter Sq under the same conditions as for ⁵

⁷ Sample size may limit this range

⁸ Without objectives

Application-specific features			
Typical flatness measurement			
Method of acquisition and evaluation	Coherence scanning on smooth surfaces ²		Coherence scanning on rough surfaces ³
Flatness deviation ^{1,4}	< 5 nm		< 30 nm
Repeatability ⁵	0.5 nm		8 nm
Typical step height measurement			
Nominal step height	7.5 µm ⁶	75 µm ⁶	20 mm ⁹
Repeatability ⁷	1.6 %	0.2 %	0.003 %
Maximum deviation of a step height measurement ^{1,8}	0.3 µm	0.7 µm	5 µm
Other features			
Measuring principle	Coherence scanning interferometry (Michelson/Mirau objectives)		
Optical setup	Microscope system; Light source: long-life LED, 525 nm		
Data formats	Topography formats: SUR, ASCII, STL, X3P Export formats: qs-STAT, PDF, BMP, PNG, TIFF, GIF		
Configuration possibilities			
Hardware included	Tip-tilt stage, Encoded turret, Precision Z drive with Continuous Scanning Technology, Integrated vibration isolation		
Hardware options	Objectives, Positioning stages: manual xy and motorized xy, Advanced focus finder, Joystick, Barcode reader, Calibration sets, Active vibration isolation breadboard		
Software included	3D data acquisition with multiple operation modes, Easy wizard, Smart Scanning Technology, Pre-scan, 2D/3D data evaluation, Automation with recipes, ISO roughness analysis (ISO 25178, ISO 4287, ISO 4288), Critical dimensions		
Software options	Environmental Compensation Technology, Quality control (QC) package, Operator Interface, Pattern matching, Software customization, MountainsMap		

¹ Complies with the initiative "Fair Data Sheet" for optical surface measurement devices

² Evaluation of the correlogram phase

³ Evaluation of the correlogram envelope

⁴ Mean value of the flatness (according to ISO 1101) from 30 measurements (10x objective, 16.5 µm/sec, 92% FOV) on a parallelly aligned plane mirror (R>93%, λ/10). Postprocessing: Alignment, 5x5 median filter with threshold 3 nm (phase evaluation)/30 nm (envelope evaluation), low pass filter λ_c=0.02mm

⁵ Standard deviation of the measured flatness values from ⁴

⁶ 15 measurements (10x objective, 16.5 µm/sec) per step on a calibrated depth setting standard, type KNT 4080/03 (ISO 5436-1)

⁷ Standard deviation of the measured step height under repeatability conditions

⁸ Largest measured deviation relative to the calibrated step height under reproducibility conditions

⁹ 15 measurements (4x objective, 16.5 µm/sec) on a calibrated gauge block (contact bonded on an optical flat) of precision class K (according to ISO 2768-2)

Configuration of the optical profiler

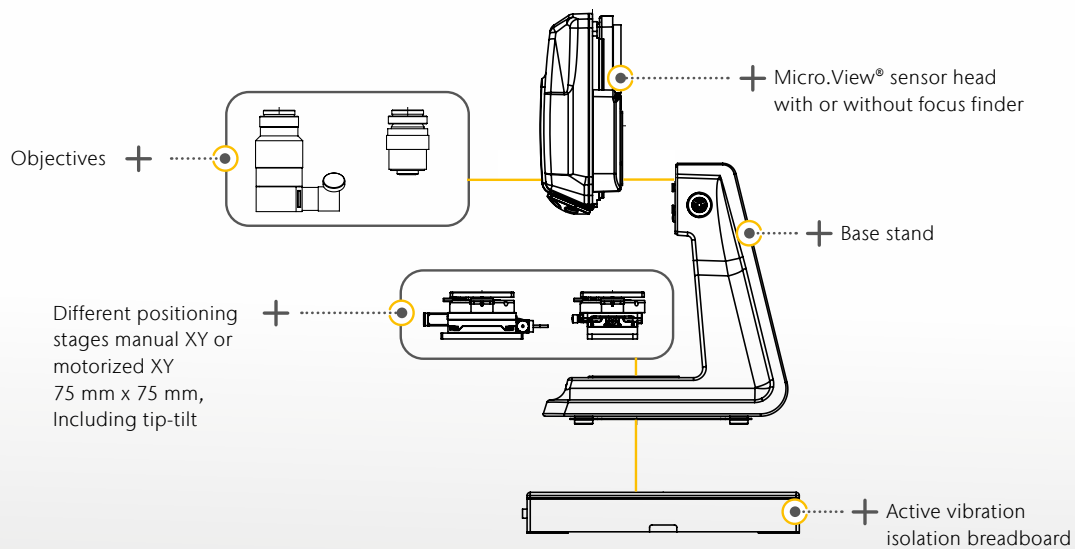

Shaping the future since 1967

High tech for research and industry.
Pioneers. Innovators. Perfectionists.

Find your Polytec representative:
www.polytec.com/contact

Polytec GmbH · Germany
Polytec-Platz 1-7 · 76337 Waldbronn